

Ojai Arts

**Cultural Heritage: Application for Certificate of Appropriateness
Proposed Materials
2022 - 0419**

County of Ventura
May 9, 2022
Cultural Heritage Board Meeting
Item 7b
Exhibit 2 – Architectural Cut Sheets, Material and
Product Selections, and Photos



SCOPE OF WORK

RESTORATION AND REFURBISHMENT OF EXISTING RETIREMENT FACILITY





- 1. WEIST ESTATE
- 2. POOL ROOM
- 3. POOL BUILDING
- 4. DOLL HOUSE
- 5. VILLA GUISEPPE MEETING ROOM
- 6. VILLA GUISEPPE MULTI-PURPOSE ROOM
- 7. CHAPEL
- 8. GARAGE SHOP

CAMPUS MAP

BUILDING KEY



BENJAMIN MOORE BAVARIAN CREAM
GENERAL EXTERIOR STUCCO

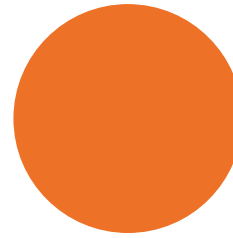

FINE PAINTS OF EUROPE
SAFETY ORANGE
DOOR ACCENT AT VILLA GIUSEPEE MEETING ROOM
AND VILLA GIUSEPEE MULTIPURPOSE ROOM



BENJAMIN MOORE BALBOA MIST
GENERAL TRIM AND WINDOW
FRAMES

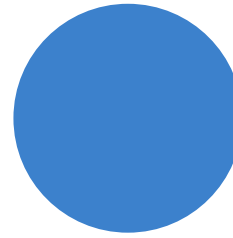

FINE PAINTS OF EUROPE
SUMMER SKY
DOOR ACCENT AT GARAGE SHOP

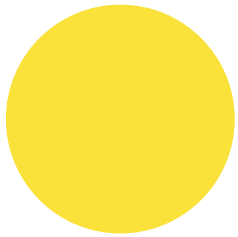

FINE PAINTS OF EUROPE
VAN GOGH YELLOW
DOOR ACCENT AT POOL BUILDING



THERMORY ASH
DECKING AT WEIST HOUSE

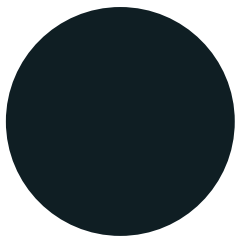

FINE PAINTS OF EUROPE
COACH GREEN
DOOR ACCENT AT WEIST ESTATE

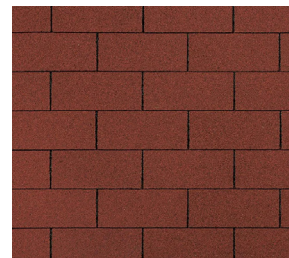

OWENS CORNING SPANISH RED ASPHALT
SHINGLES
RESTORED ROOF AT POOL HOUSE, DOLL HOUSE,
AND GARAGE SHOP

HISTORIC COLOR SCHEME AND MATERIALS

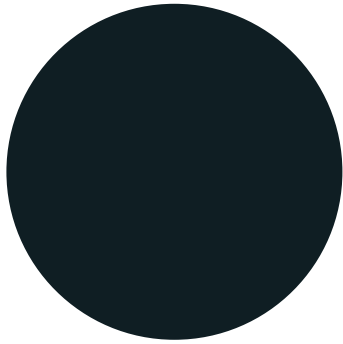

PAINT EXISTING DOOR:
FINE PAINTS OF EUROPE
COACH GREEN



PAINT EXISTING STUCCO:
BENJAMIN MOORE
BAVARIAN CREAM

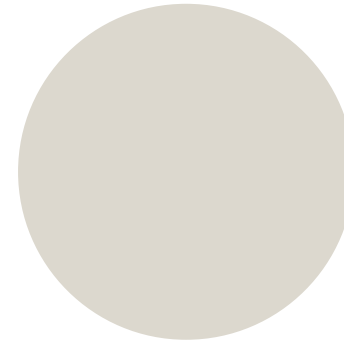

PAINT EXISTING TRIM:
BENJAMIN MOORE
BALBOA MIST



EXTERIOR DECKING
THERMORY
ASH 1X6 BOARDS



EXISTING ROOF SHINGLES TO
REMAIN

1

WEIST ESTATE

PAINT COLORS AND DECKING

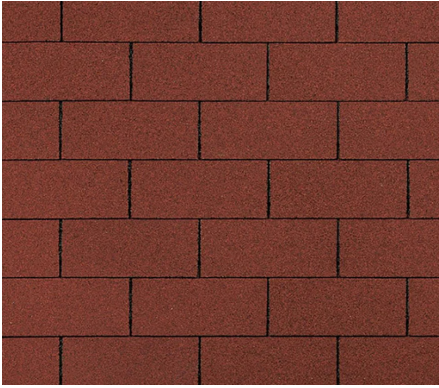

REPLACE DAMAGED ROOF:
OWENS CORNING SPANISH RED
ASPHALT SUPREME SHINGLES

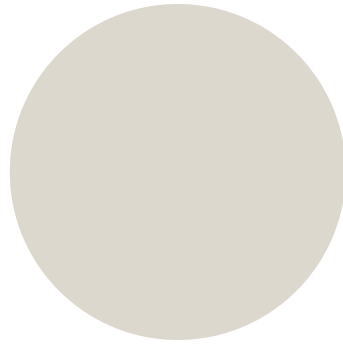

PAINT EXISTING TRIM:
BENJAMIN MOORE
BALBOA MIST



PAINT EXISTING STUCCO:
BENJAMIN MOORE
BAVARIAN CREAM

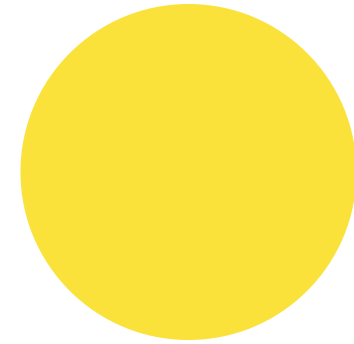

DOORS PAINT:
FINE PAINTS OF EUROPE
VAN GOGH YELLOW

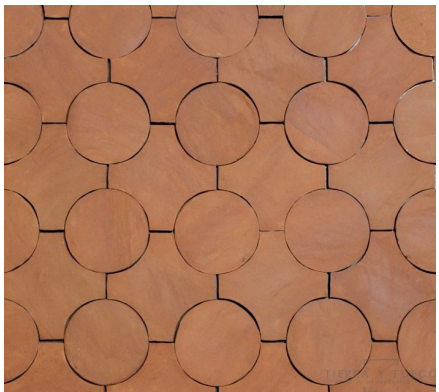

EXTERIOR PORCH TILE
TIERRA Y FUEGO
TERRACOTTA TILE
UNGLAZED

2&3

POOL ROOM

ROOF SHINGLES, PAINT COLORS, AND TILE

**BESTOR
ARCHITECTURE**

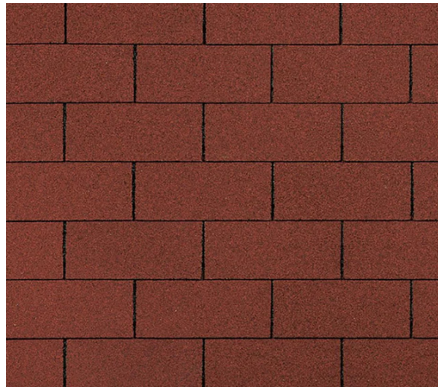

REPLACE DAMAGED ROOF:
OWENS CORNING SPANISH RED
ASPHALT SUPREME SHINGLES



PAINT EXISTING TRIM:
BENJAMIN MOORE
BALBOA MIST



PAINT EXISTING STUCCO:
BENJAMIN MOORE
BAVARIAN CREAM

4

DOLL HOUSE

ROOF SHINGLES AND PAINT COLORS



EXISTING ROOF SHINGLES TO
REMAIN



PAINT EXISTING TRIM:
BENJAMIN MOORE
BALBOA MIST



PAINT EXISTING STUCCO:
BENJAMIN MOORE
BAVARIAN CREAM

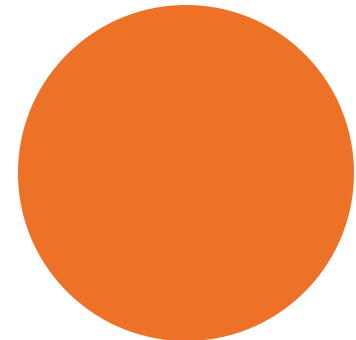

DOORS PAINT:
FINE PAINTS OF EUROPE
SAFETY ORANGE

5

VILLA GIUSEPPE MEETING ROOM

PAINT COLORS



EXISTING ROOF SHINGLES TO
REMAIN



PAINT EXISTING TRIM:
BENJAMIN MOORE
BALBOA MIST



PAINT EXISTING STUCCO:
BENJAMIN MOORE
BAVARIAN CREAM

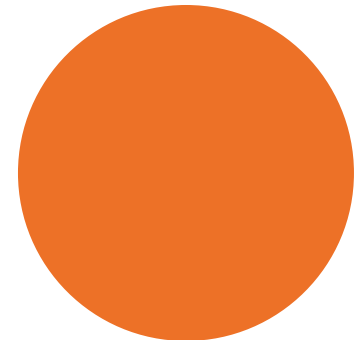

DOORS PAINT:
FINE PAINTS OF EUROPE
SAFETY ORANGE

6

VILLA GIUSEPPE MULTI-PURPOSE ROOM

PAINT COLORS

OPTION 1

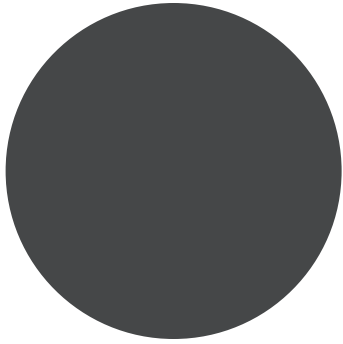

PAINT EXISTING TRIM:
BENJAMIN MOORE
GRAPHITE



PAINT EXISTING STUCCO:
BENJAMIN MOORE
BAVARIAN CREAM



EXISTING ROOF SHINGLES TO
REMAIN



T&G SIDING & DOOR
CVG WESTERN RED

OPTION 2

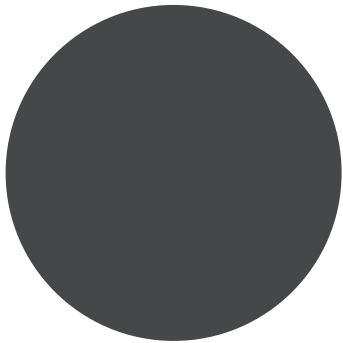

PAINT EXISTING TRIM:
BENJAMIN MOORE
GRAPHITE

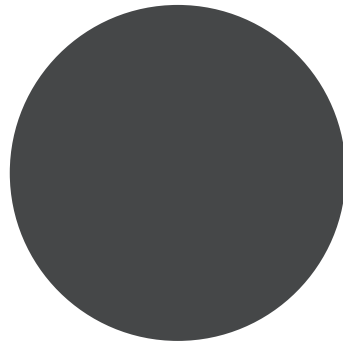

PAINT EXISTING STUCCO:
BENJAMIN MOORE
GRAPHITE



EXISTING ROOF SHINGLES TO
REMAIN

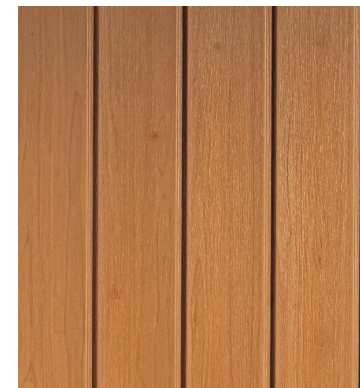

T&G SIDING & DOOR
CVG WESTERN RED

7

CHAPEL

PAINT COLORS AND WOOD SIDING/DOOR



REPLACE DAMAGED ROOF:
OWENS CORNING SPANISH RED
ASPHALT SUPREME SHINGLES



STUCCO PAINT:
BENJAMIN MOORE
BAVARIAN CREAM

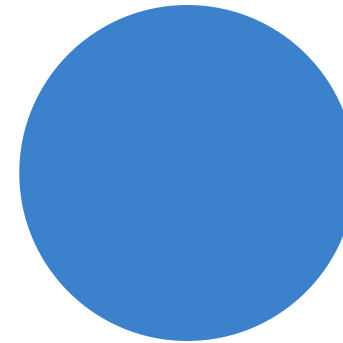

DOORS PAINT:
FINE PAINTS OF EUROPE
SUMMER SKY



REPLACE DAMAGED ROOF:
OWENS CORNING SPANISH RED
ASPHALT SUPREME SHINGLES



STUCCO PAINT:
BENJAMIN MOORE
BAVARIAN CREAM

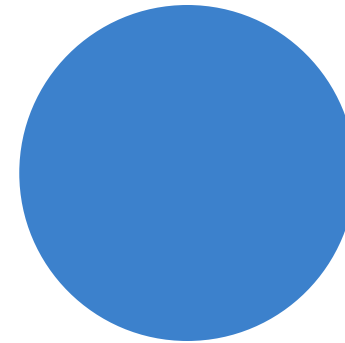

DOORS PAINT:
FINE PAINTS OF EUROPE
SUMMER SKY



SUPREME[®] Shingles



Desert Tan⁺



TOTAL PROTECTION. TOTAL CONFIDENCE.[®]



SEAL.



DEFEND.



BREATHE.

Supreme® Shingles

Supreme® three-tab shingles—a smart choice when you need to balance curb appeal, weather resistance and value. *Supreme* shingles come with a 25-Year Limited Warranty*, 60-MPH Wind Resistance Limited Warranty*, and Class A UL Fire Resistance—the industry's highest. StreakGuard™ Protection with a 10-year Algae Resistance Limited Warranty is also available on a regional basis. Visit owenscorning.com/roofing to learn more.

ENERGY STAR® is for roofs too



Similar to the energy-efficient appliances in your home, roofing products can help provide energy-saving qualities. Owens Corning® *Supreme* roofing shingles in Shasta White can help reduce your heating and cooling bills when installed properly. These shingles reflect solar energy, helping to decrease the amount of heat transferred to a home's interior—and the amount of air conditioning needed to keep it comfortable. Actual savings will vary based on geographic location and individual building characteristics. Call 1-800-GET-PINK® or 1-888-STAR-YES for more information.

Product Attributes

Warranty Length*

25-Year Limited

Wind Resistance Limited Warranty*

60 MPH

Algae Resistance Limited Warranty*

10 Years

TRU PROtection® Non-Prorated Limited Warranty* Period

5 Years

Product Specifications

Size 12" x 36"

Application Exposure 5"

Shingles per Bundle Not less than 26

Average Shingle Count per 3 Bundles 80

Average Coverage per 3 Bundles 100 sq. ft.

Applicable Standards and Codes

ASTM D228

ASTM D3018 (Type 1)

ASTM D3161 (Class F Wind Resistance)

ASTM D3462

ASTM D7158 (Class H Wind Resistance)

ASTM E108/UL 790 (Class A Fire Resistance)

Florida Product Approval†

ICC-ES AC438#

Miami-Dade County Product Approval**

PRI ER 1378E01

Shasta White color meets ENERGY STAR® requirements for initial solar reflectance of 0.25 and 3-year aged solar reflectance of 0.15; 2013 California Building Energy Efficiency Standards; Title 24, Part 6 requirements; Rated by the Cool Roof Rating Council (CRRC).

COLORS AVAILABLE IN ALL AREAS

ROOF SHINGLES



Aspen Gray†



Autumn Brown†



Brownwood†



Desert Tan†



Driftwood†



Estate Gray†

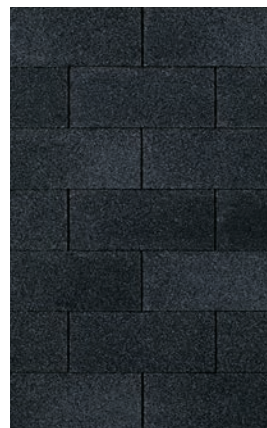

Onyx Black†



Shasta White†

ADDITIONAL REGIONAL COLORS (See chart and map for availability)

ROOF SHINGLES

	1	2	3	4	5	6	7	8	9	10	11	12
Amber [†]										●	●	●
Antique Silver [†]			●			●						
Beachwood Sand [†]			●			●						
Chateau Green [†]	●	●	●	●	●	●	●	●	●	●		
Forest Green [†]										●		
Spanish Red [†]						●				●		
Teak [†]				●	●	●	●	●		●		
Weathered Wood [†]		●	●		●	●	●	●		●		
Williamsburg Gray [†]		●				●						



Amber[†]



Antique Silver[†]



Beachwood Sand[†]



Chateau Green[†]



Forest Green[†]

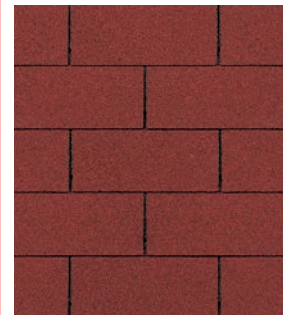

Spanish Red[†]

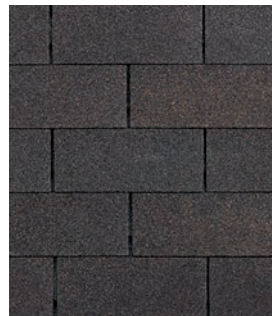

Teak[†]



Weathered Wood[†]



Williamsburg Gray[†]

REGIONAL COLOR AVAILABILITY MAP

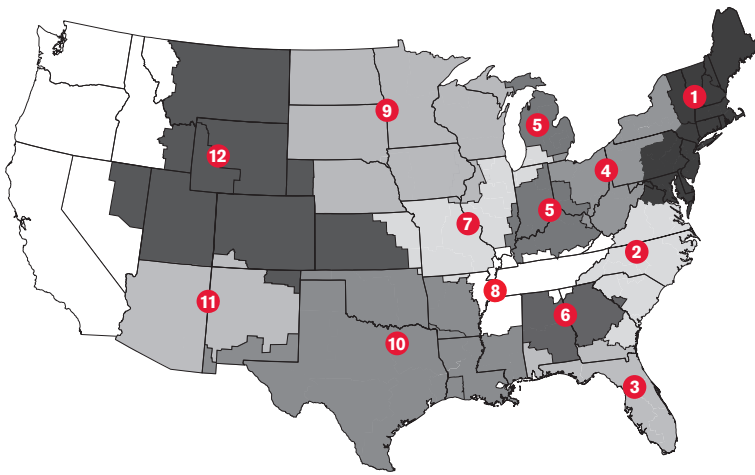

* See actual warranty for complete details, limitations and requirements.
[†] Actual colors and granule blends may vary from the photo. We suggest that you view actual product on the roof to get a better idea of the finish color. Color availability subject to change without notice. Ask your professional roofing contractor for samples of colors available in your area.
^{††} Applies for all areas that recognize a Miami-Dade Notice of Acceptance (NOA).
[‡] Applicable only in Service Area 3 (see map).
[#] International Code Council Evaluation Services Acceptance Criteria for Alternative Asphalt Shingles. ENERGY STAR and the ENERGY STAR mark are registered trademarks of the U.S. Environmental Protection Agency.
[^] Excludes non-Owens Corning[®] roofing products such as flashing, fasteners, pipe boots and wood decking.
 Disclaimer of Liability
 Technical information contained herein is furnished without charge or obligation and is given and accepted at recipient's sole risk. Because conditions of use may vary and are beyond our control, Owens Corning makes no representation about, and is not responsible or liable for the accuracy or reliability of data associated with particular uses of any product described herein.



Total Protection Roofing System^{®^}

TOTAL PROTECTION SIMPLIFIED™



Owens Corning® Total Protection Roofing System^{®^} integrates engineered Owens Corning® components that work together to address these three primary performance areas, critical to a high-performance roof, while also making it easy to understand the importance of each. **With Owens Corning, it's easy to confidently deliver total protection, beauty and peace of mind.**

SEAL.

- SELF-ADHERED ICE & WATER BARRIER
- SYNTHETIC UNDERLAYMENT

DEFEND.

- STARTER SHINGLES
- LAMINATE SHINGLES
- HIP & RIDGE SHINGLES

BREATHE.

- INTAKE VENTS
- EXHAUST VENTS

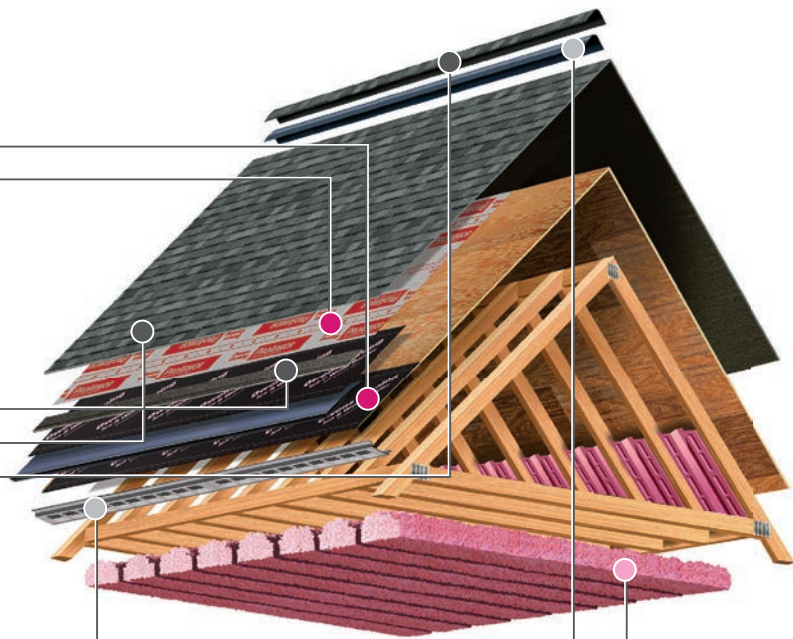

+ COMFORT.

PINK® FIBERGLAS™
BLOWN-IN
ATTIC INSULATION



OWENS CORNING ROOFING AND ASPHALT, LLC
ONE OWENS CORNING PARKWAY
TOLEDO, OHIO, USA 43659
1-800-GET-PINK®
www.owenscorning.com/roofing



Pub. No. 10013324-I. Printed in U.S.A. October 2019.
THE PINK PANTHER™ & © 1964–2019 Metro-Goldwyn-Mayer Studios Inc.
All Rights Reserved. The color PINK is a registered trademark of Owens Corning.
© 2019 Owens Corning. All Rights Reserved.

(Atlanta, Brookville, Denver, Irving East, Irving West, Jacksonville, Kearny, Medina, Memphis, Minneapolis, Savannah, Summit)



**THERMORY DECKING
AT WEIST ESTATE**



« View All Products

FIND YOUR DISTRIBUTOR

GET A SAMPLE



APPLICATION:

STANDARD STOCK

SPECIES:

WHITE ASH

FINISH

STRENGTH:

UNFINISHED

TEXTURE:

SMOOTH

WIDTH:

5.2 INCHES

INSTALLATION

TYPE:

VISIBLE

USE:

INTERIOR,
EXTERIOR

COLOR:

BROWN

FINISH:

UNOILED

THICKNESS:

0.79 INCHES

COVERAGE:

5.2 INCHES

PROFILE:

T&G

INSTALLATION METHOD: SCREW

REQUEST A SAMPLE

OVERVIEW/DRAWINGS AND BIM

INSTALLATION

MAINTENANCE

MODIFICATION

▶ Download Drawing (PDF)

▶ Download Drawing (DWG)

▶ Download BIM/Revit & Specs

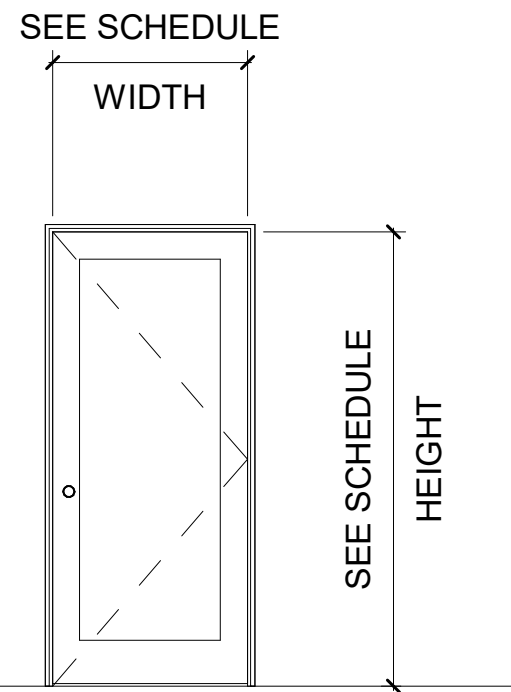

DOOR TYPE A1 - SGL SWING - SINGLE PANEL DOOR
LOCATED AT WEIST ESTATE OUTDOOR HALLWAY
(DOORS 405.1 & 406.1)

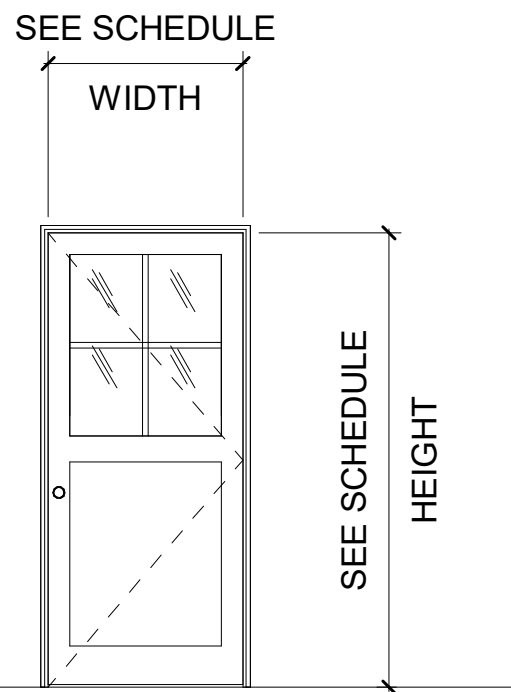

DOOR TYPE A3 - SGL SWING HALF LITE PANEL
LOCATED AT WEIST ESTATE UNITS & LAUNDRY ROOM
(DOORS 407.1, 410.2, 413.2, 416.2)



REFERENCE PHOTO

ORIGINAL SINGLE PANEL
EXTERIOR DOOR



REFERENCE PHOTO

NEW SINGLE SWING HALF LITE DOOR TO MATCH
ORIGINAL DETAILS OF HISTORIC WINDOW

WEIST ESTATE DOORS

NEW CUSTOM WOOD PAINTED EXTERIOR DOOR TO MATCH ORIGINAL DETAILS AND PROFILES

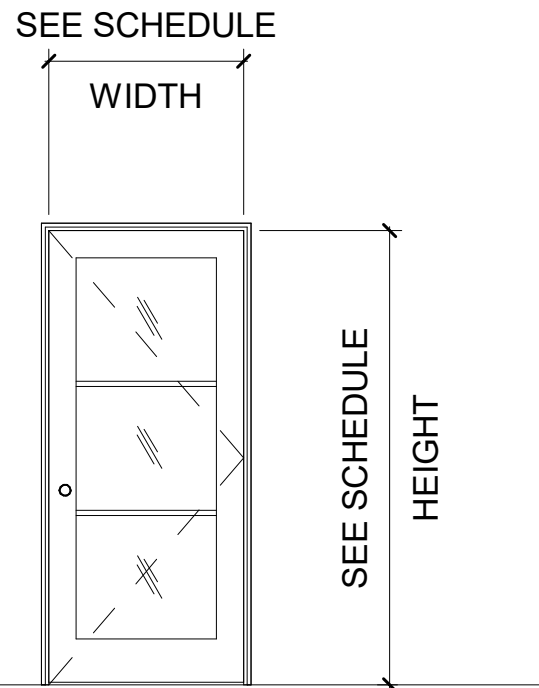

DOOR TYPE A4 - SGL SWING W/ LITE
 LOCATED AT WEIST ESTATE DINING HALL
 (DOORS 418.1, 418.2, 418.3)



REFERENCE PHOTO

ORIGINAL EXTERIOR DOOR

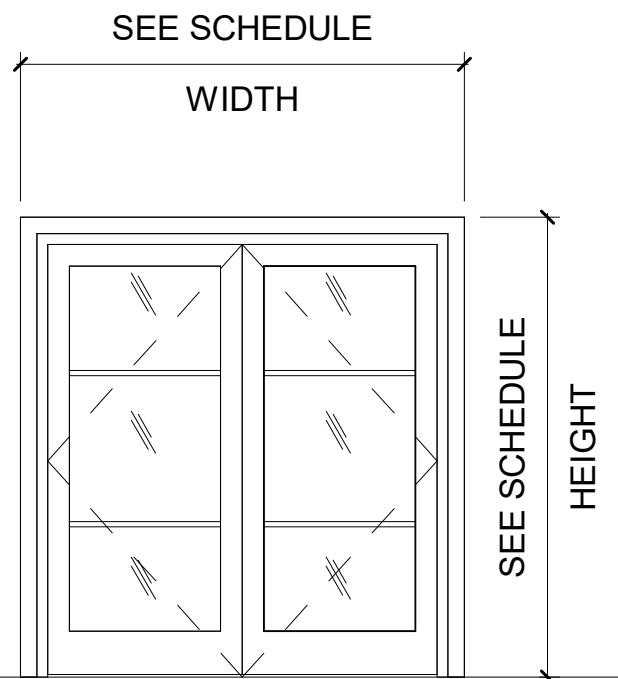

DOOR TYPE E2 - DBL SWING W/ LITE
 LOCATED AT WEIST ESTATE KITCHEN & DINING HALL)
 (DOORS 400.1, 418.4, 418.5, & 418.6)



REFERENCE PHOTO

NEW DOUBLE SWING WITH LITE DOOR TO MATCH ORIGINAL DETAILS OF HISTORIC WINDOW

WEIST ESTATE DOORS

NEW CUSTOM WOOD PAINTED EXTERIOR DOOR TO MATCH EXISTING DETAILS AND PROFILES

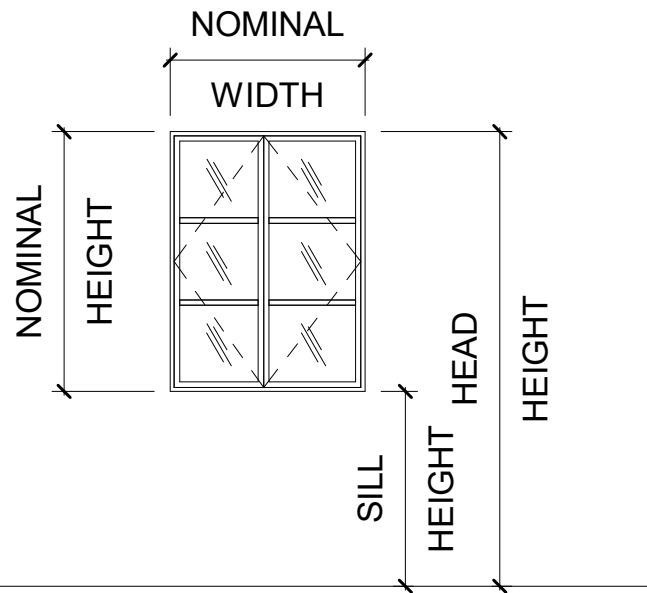

WINDOW TYPE B2 - 2 PANEL CASEMENT
 LOCATED AT WEIST ESTATE DINING HALL
 (WINDOWS 418.A, 418.B, 418.C, 418.D)

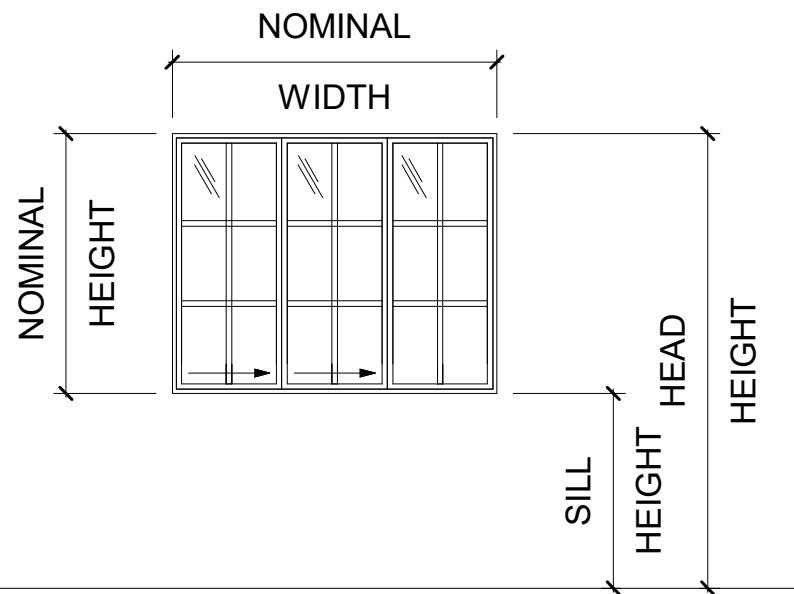

DOOR TYPE F1 - 3 PANEL SLIDER
 LOCATED AT WEIST ESTATE DINING HALL)
 (WINDOW 403.A)



REFERENCE PHOTO

ORIGINAL EXTERIOR WINDOW



REFERENCE PHOTO

NEW SLIDER TO MATCH HISTORIC CASEMENTS

WEIST ESTATE WINDOWS

NEW CUSTOM WOOD PAINTED EXTERIOR WINDOWS TO MATCH ORIGINAL DETAILS AND PROFILES

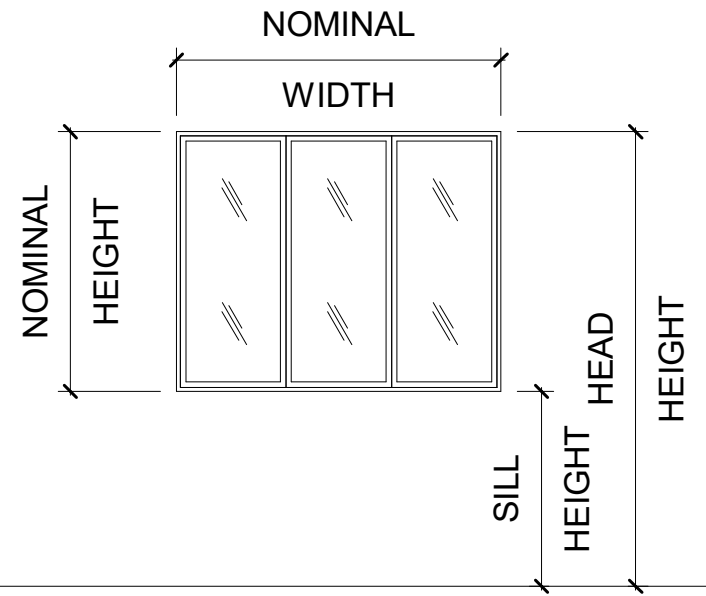

WINDOW TYPE C1 - FIXED MULTI-PANEL
 LOCATED AT WEIST ESTATE OUTDOOR HALLWAY
 (WINDOWS 400.C & 400.F)



REFERENCE PHOTO

ORIGINAL FIXED WINDOW

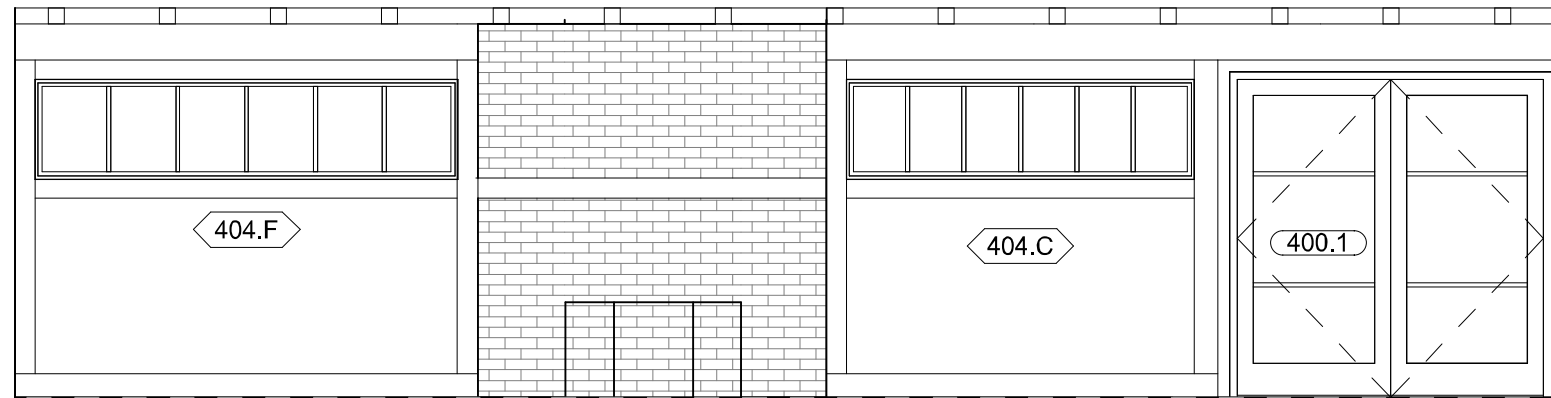

REFERENCE EXTERIOR ELEVATION

WEIST ESTATE WINDOWS

NEW CUSTOM WOOD PAINTED EXTERIOR WINDOWS TO MATCH ORIGINAL DETAILS AND PROFILES



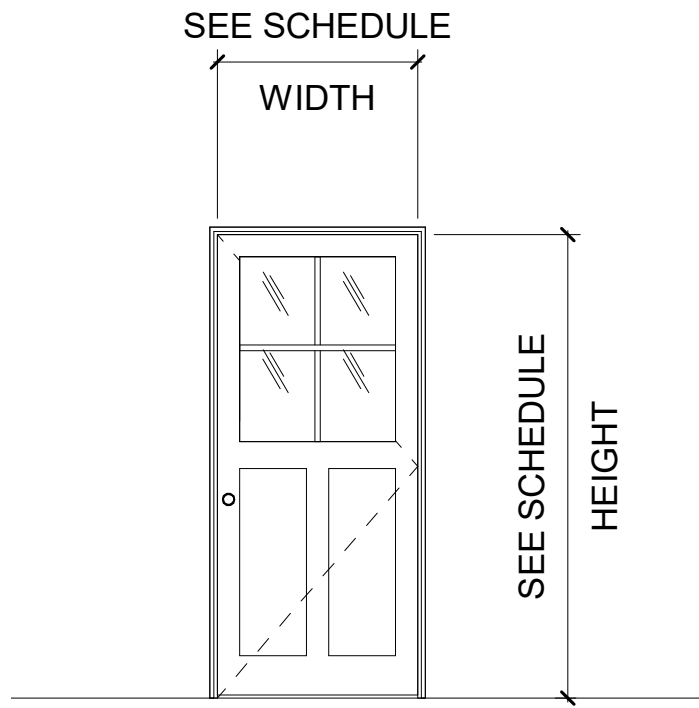

DOOR TYPE A3 - SGL SWING HALF LITE PANEL
 LOCATED AT POOL HOUSE UNITS & LAUNDRY ROOM
 (DOORS 304.1, 307.2, 312.2, 316.2)



REFERENCE PHOTO

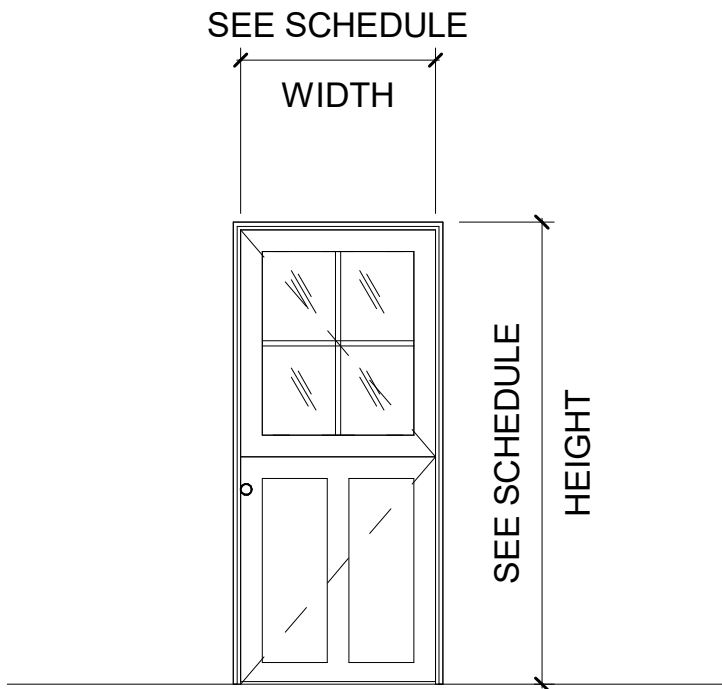

DOOR TYPE C1 - SGL SWING DUTCH WITH LITE
 LOCATED AT POOL HOUSE UNITS
 (DOORS 306.1, 309.1, 313.1, & 317.1)



REFERENCE PHOTO

ORIGINAL EXTERIOR DOOR

POOL HOUSE DOORS

NEW CUSTOM WOOD PAINTED EXTERIOR DOOR TO MATCH ORIGINAL DETAILS AND PROFILES

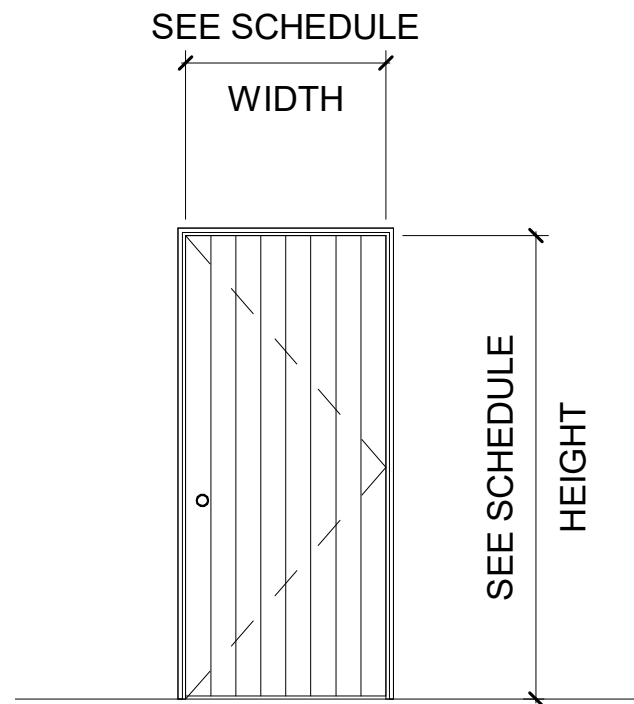

DOOR TYPE A5 - SGL SWING PLANK PANEL
LOCATED AT POOL ROOM & POOL HOUSE
(DOORS 300.1, 301.1, 302.1)

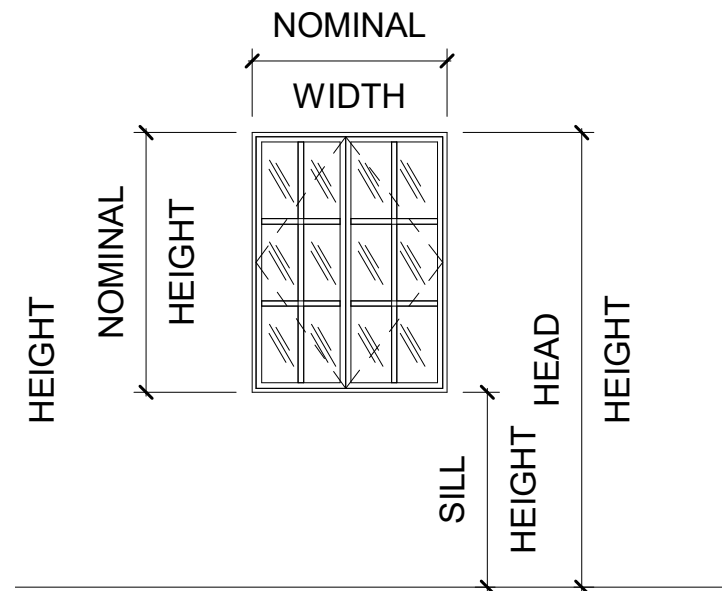

WINDOW TYPE B1 - 2 PANEL CASEMENT
LOCATED AT POOL HOUSE UNITS
(WINDOWS 313.A, 317.A)



REFERENCE PHOTO

ORIGINAL EXTERIOR DOOR



REFERENCE PHOTO

ORIGINAL EXTERIOR WINDOW

POOL HOUSE DOOR & WINDOW

NEW CUSTOM WOOD PAINTED EXTERIOR DOOR & WINDOW TO MATCH ORIGINAL DETAILS AND PROFILES

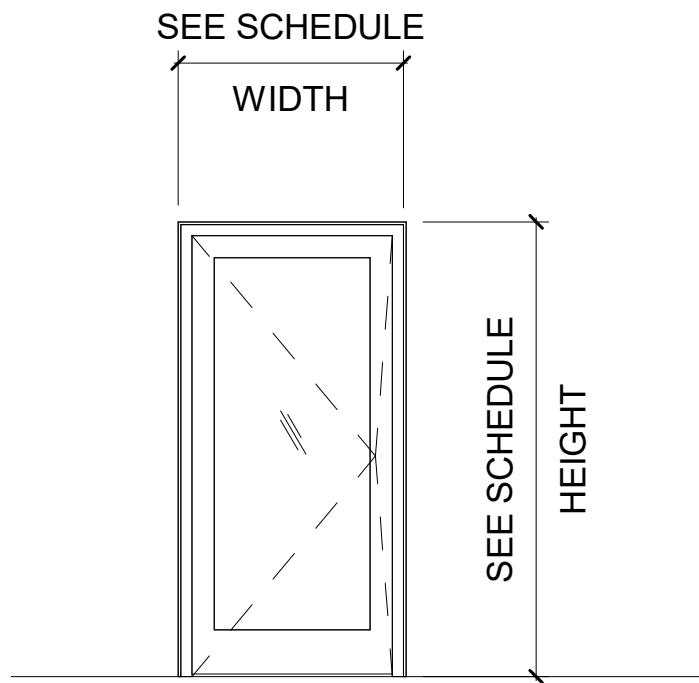

DOOR TYPE B2 - PIVOT DOOR WITH LITE
 LOCATED AT CHAPEL ENTRY DOOR
 (DOOR 500.1)

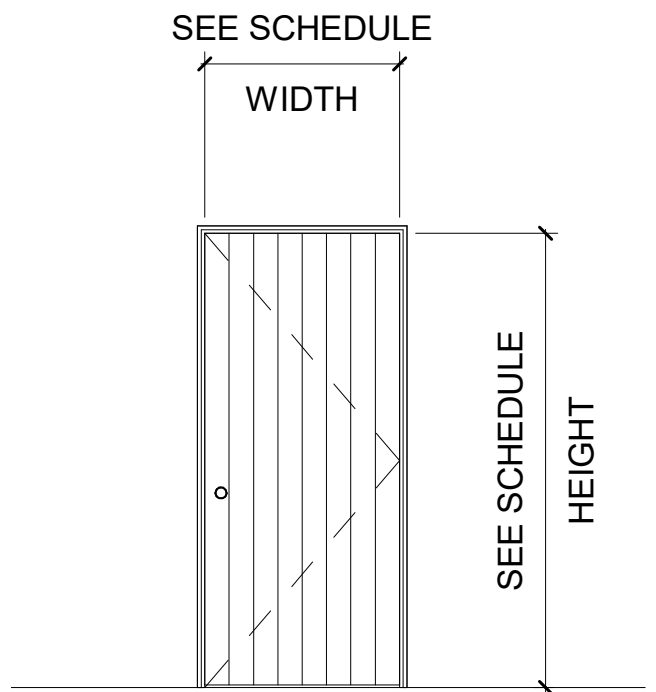

DOOR TYPE A5 - SGL SWING PLANK PANEL
 LOCATED AT CHAPEL ENTRY DOOR
 (DOOR 501.1)

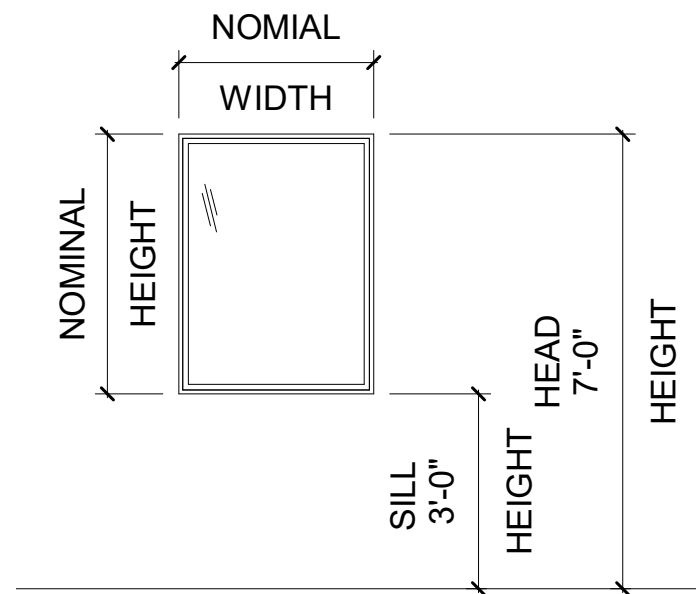

WINDOW TYPE A1 - FIXED
 LOCATED AT CHAPEL ENTRY
 (WINDOW 500.A)



REFERENCE PHOTO

T&G SIDING AND DOOR TO MATCH ORIGINAL T&G
 DECKING AT EXISTING EAVES

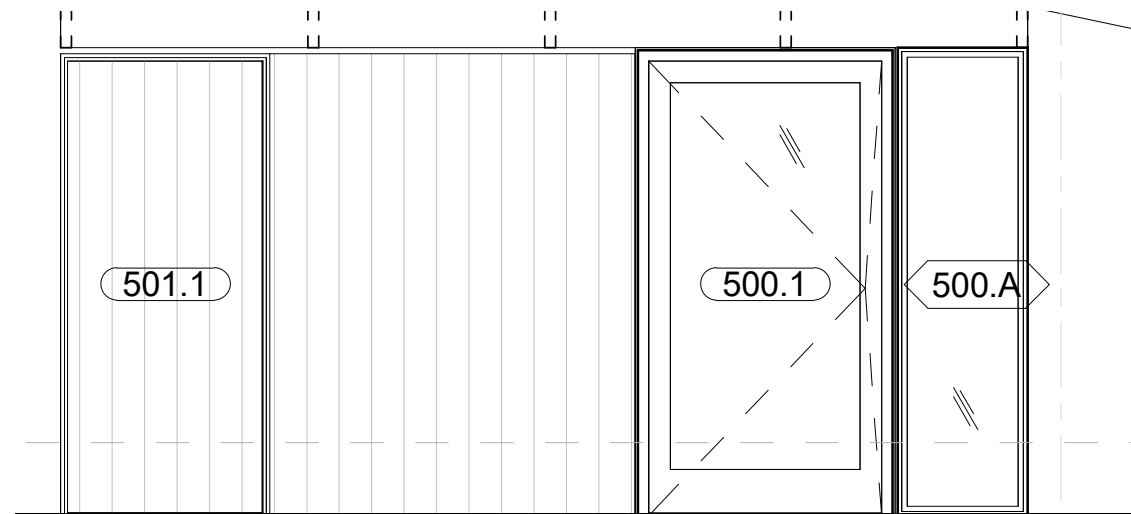

CHAPEL ENTRY ELEVATION

CHAPEL DOORS

NEW CUSTOM WOOD EXTERIOR DOOR TO MATCH ORIGINAL DETAILS

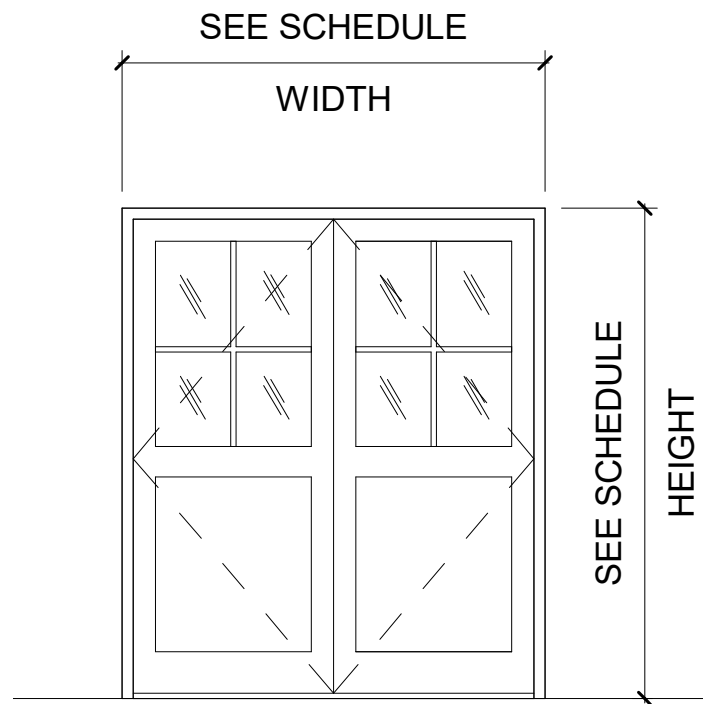

DOOR TYPE E1 - DBL SWING W/ HALF LITE
(DOOR 603.1)

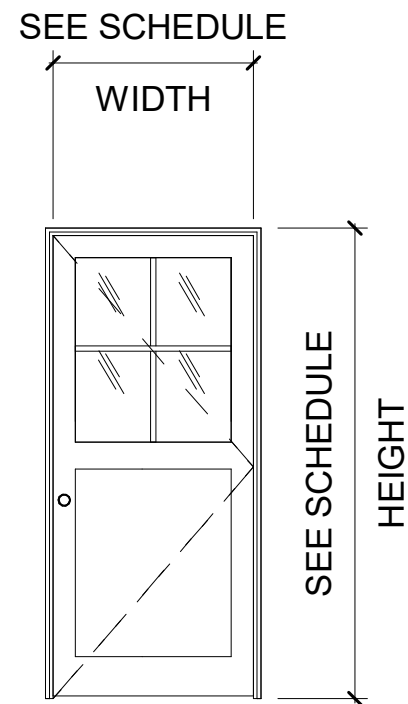

DOOR TYPE A3 - SGL SWING HALF LITE PANEL
(DOORS 601.1, 602.2, 606.1)



REFERENCE PHOTO

LITE DIVISION & STICKING
PROFILE REF.

VILLA GIUSEPPE MEETING ROOM DOORS

NEW CUSTOM WOOD PAINTED EXTERIOR DOOR TO MATCH ORIGINAL DETAILS AND PROFILES

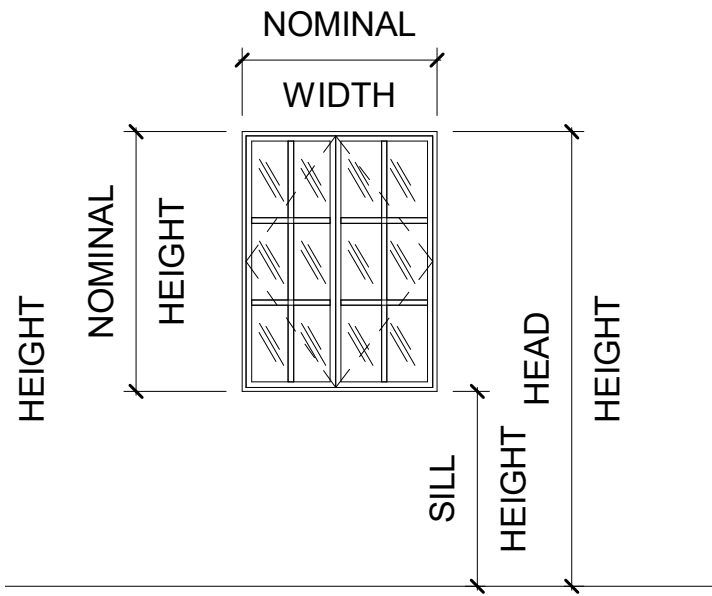

**WINDOW TYPE B1 - 2 PANEL CASEMENT
 LOCATED AT SCREENED PORCH
 (WINDOWS 602.A, 602.B, 602.C)**



REFERENCE PHOTO

ORIGINAL EXTERIOR WINDOW

VILLA GIUSEPPE MEETING ROOM WINDOWS

NEW CUSTOM WOOD EXTERIOR WINDOW TO MATCH EXISTING DETAILS AND PROFILES

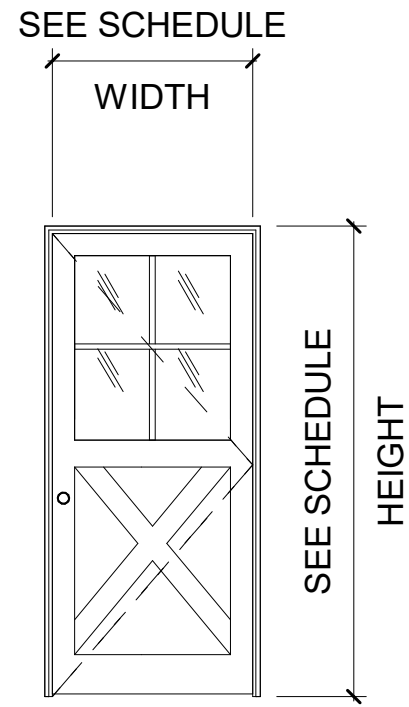

DOOR TYPE A3 - SGL SWING HALF LITE PANEL
(DOOR 706.1)

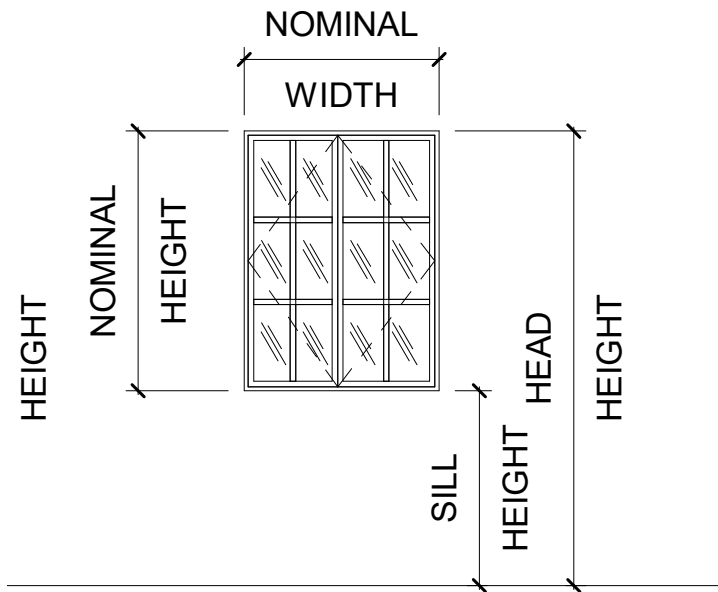

WINDOW TYPE B1 - 2 PANEL CASEMENT
(WINDOW 701.A)



REFERENCE PHOTO

ORIGINAL EXTERIOR DOORS



REFERENCE PHOTO

ORIGINAL EXTERIOR WINDOW

VILLA GIUSEPPE MULTI-PURPOSE ROOM DOOR & WINDOW

NEW CUSTOM WOOD PAINTED EXTERIOR DOOR & WINDOW TO MATCH ORIGINAL DETAILS AND PROFILES

EXTERIOR SCONCE
AT WEIST ESTATE &
POOL HOUSE UNIT
DOORS

REJUVENATION



Carson 12" Wall Sconce

Matte Cream

Item #A1296

<http://www.rejuvenation.com/s/18fla>

Specification	Detail
Item #	A1296
Width	11-1/2"
Height	13"
Projection	16"
Canopy Diameter	5"
Number of Sockets	1
Wattage	100W

Price as shown* : \$269.00

*Shipping and handling fees apply

SPR7BOSSTADA



32.25" x 23.75" x 25" (H x W x D)

ADA compliant commercial outdoor refrigerator in complete stainless steel, designed for built-in or freestanding use

Highlights:

- 32" height allows installation under lower ADA compliant counters
- U.L. approved for outdoor use with a weatherproof design
- ETL-S listed to NSF-7 commercial standards

Product Features:

ADA compliant	32" height is designed to fit under lower ADA compliant counters
Approved for outdoor use	Weatherproof design rated safe for outdoor operation
Commercially listed	ETL-S listed to NSF-7 Standards for use in commercial establishments
304 grade stainless steel exterior	Complete stainless steel construction for easy durability in the outdoors
Built-in capable	Make the best use of space by installing your unit under the counter and flush with other cabinets
Automatic defrost	Reduced maintenance with auto defrost system
Factory installed lock	Keyed lock for a secure interior
Ground Fault Circuit Interrupter	Our integrated GFCI exceeds U.L. requirements for safety by protecting your unit from shocks and circuit breaks
Professional towel bar handle	A curved stainless steel handle adds function and elegance, providing more room for a comfortable grip



SPR7BOSSTADA Specifications:

Overview	
Height of Cabinet	32.0" (81 cm)
Height to Hinge Cap	32.25" (82 cm)
Width	23.75" (60 cm)
Depth	25.0" (64 cm)
Depth with Handle	27.5" (70 cm)
Capacity	5.5 cu.ft. (156 L)
Defrost Type	Automatic
Door	Stainless Steel
Cabinet	Stainless Steel
US Electrical Safety	ETL
Canadian Electrical Safety	ETL-C
Sanitation	ETL-S
Amps	1.2
Voltage/Frequency	115 V AC/60 Hz
Shipping Weight	127.0 lbs. (58 kg)
Parts & Labor Warranty	1 Year
Compressor Warranty	5 Years
UPC	761101069425
Refrigerator Features	
Door Swing	RHD
Reversible	Factory Reversible
Shelf Type	Glass
Shelf Qty	3
Adjustable Shelves	Yes
Thermostat Type	Dial
Fan Type	Exterior
Refrigerant Type	R600a
Refrigerant Amount	0.64oz.
High Side PSI	180.0
Low Side PSI	80.0

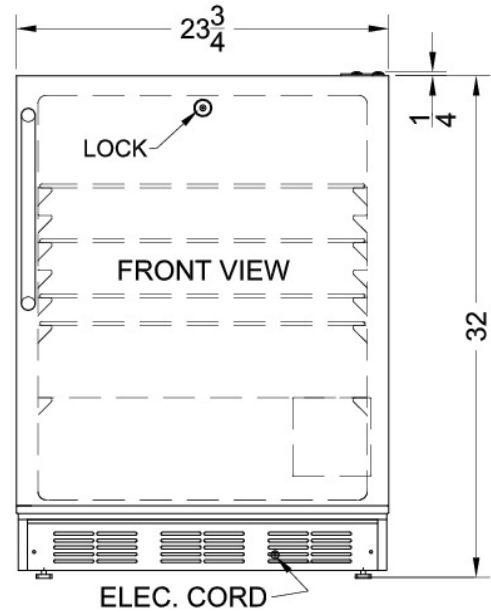
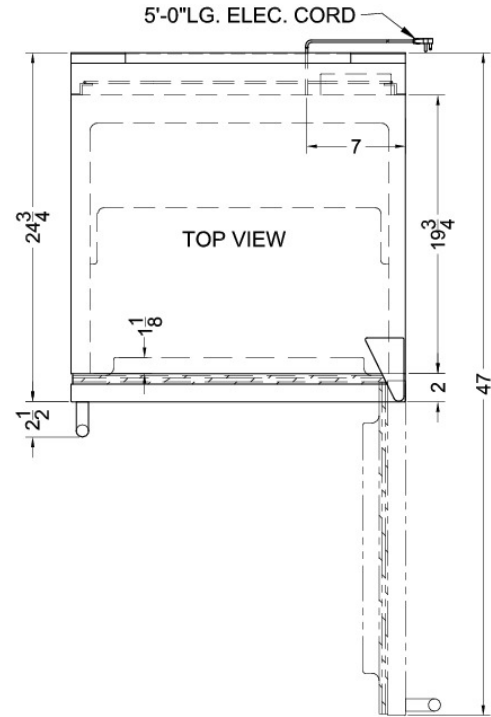

36" Grill, Natural Gas

Series 7

Stainless Steel | Natural gas



Designed with flexibility in mind, DCS Grills allow you to cook a wide variety of meals and are engineered to deliver the functionality and power demanded by a professional chef. DCS Grills are hand-finished to perfection to complement the quality of the DCS premium outdoor kitchen and built to withstand the demands of the serious cook and the extremes of mother nature. Available in Natural and LP Gas. Grill Cart pictured sold separately.

NATURAL GAS GRILL AT WEIST ESTATE GRILL

DIMENSIONS

Height	24 1/4"
Width	35 7/8"
Depth	26 5/8"

FEATURES & BENEFITS

Precision heat and control

A DCS Grill puts you in control of up to a massive 92,500 BTU per hour total power. That power lets you choose the precise heat you need from a low and slow 300° up to an intense 1100°. DCS Grills do more than help you grill an incredible steak, you can infuse smoke into your favorite meal using the built in smoker, or close the specially designed hood and use the power of convection to cook the perfect pizza. DCS Grills put you in control, giving you the versatility to cook what you want.

Double-sided Cast Stainless Steel Grates

One side has a gentle radius for handling delicate foods. The other side is W-shaped for perfect sear lines while channeling oil away to an easily removable drip tray.

Grease Management System™ Grease Channeling Technology

This patented technology reduces flare-ups by directing grease and oils away from the burner flames during grilling.

Smart Beam™ Grill Light

A halogen light is designed to illuminate the entire cooking surface for perfect night grilling.

Temperature Gauge

Designed for monitoring temperatures when cooking pizzas or when using indirect heat from adjacent burners, for preparing roast meals.

Dedicated Sealed Smoker

A dedicated smoker tray with a direct 3,500BTU burner offering a clean, convenient option for specialized smoking recipes.

SPECIFICATIONS

Accessories

6" accessory storage	ASH6-36
Built-in grill cover	ACBI-36
Griddle plate	BGC-GP
Hybrid IR burner	BGC-IR
Insulated jacket	BGA36-IJS (optional)
Insulated jacket (if accessory)	BGA42-IJS (optional)
On cart grill cover	ACC-36
Optional cart mount	CAD1-36

Burners

Number of U-burners	3
---------------------	---

Cooking Surface Area

Primary cooking area	630sq.in.
Total cooking area	871sq.in.
Warming rack area	241sq.in.

Features

Double sided Stainless Steel	•
Full surface searing	•
Grease management system™	•
Hood temperature gauge	•
Ignition system	Spark
Metal dials	•

Rotisserie	•
Smoker	•
Warming rack	•

Finish

Material	304 grade stainless steel
Weather resistant	•

Gas Requirements

1/2" NPT male with 3/8" in flare	•
Gas type	NG
Operational pressure	4" W.C.
Supply Pressure	6" to 9" W.C.

Installation Dimensions

Cutout depth (proud)	22 3/4"
Cutout height (proud)	10 1/8"
Cutout width (proud)	34 1/2"
Insulated jacket for proud cut-	Varies - check manual

Performance

Griddle power	25000 BTU
Rotisserie burner power	14000 BTU
Smoker burner power	3500 BTU
Total Power	92500 BTU
Weight rotisserie can handle	50lbs

Power requirements

Grill power supply	9V Battery for Ignition
Rotisserie power supply	120V 60Hz

Product dimensions

Depth	26 5/8"
Height	24 1/4"
Width	35 7/8"



Warranty

Parts and labor	2 years
-----------------	----------------

SKU	71448
-----	-------

The product dimensions and specifications in this page apply to the specific product and model. Under our policy of continuous improvement, these dimensions and specifications may change at any time. You should therefore check with Fisher & Paykel's Customer Care Centre to ensure this page correctly describes the model currently available. ? DCS by Fisher & Paykel Appliances Limited 2020

Other product downloads available at [dcsappliances.com](https://www.dcsappliances.com)

-  Service and Warranty
-  User Guide
-  Installation Guide

A PEACE OF MIND SALE

24 Hours 7 Days a Week Customer Support

T 1.888.936.7872 W www.dcsappliances.com